

Belifu

TENS
Pain Relief, Anywhere Anytime



YF1503

Pain Relief, Anywhere, Anytime.

Please read the instructions manual carefully before using the device.



Manufacturer: Shenzhen Yuehua Xinsen Technology Co.,Ltd
Address: No. 27-201, Zhongwu 3rd Road, Zhongwu Community, Hangcheng Street, Bao'an District, Shenzhen City, Guangdong Province.CHINA. 518100

Customer Service:

✉ support@belifu.com

Please download the PDF manual on the below link:

<https://belifu.com/downloads/>

Precaution

- Please read the instructions manual carefully before using the device.
If you have any questions, please refer to the salesman or ask your doctor.
- Please keep this manual for future reference.

TABLE OF CONTENTS

1. INTRODUCTION
2. SAFETY INTRODUCTIONS
3. FUNCTIONS OF THE DEVICE
4. OPERATING INSTRUCTIONS
5. BATTERY AND MEMORY FUNCTION
6. MAINTENANCE
7. MODE INSTRUCTION
8. TENS EMS ELECTRODE
PLACEMENT GUIDE
9. TROUBLESHOOTING
10. PRODUCT DESCRIPTIONS
11. MEDICAL DISCLAIMER
12. PRECAUTIONS
13. CONTRAINDICATIONS
14. ADVERSE REACTION
15. NOTES ON FCC CERTIFICATION
16. WARRANTY

1.INTRODUCTION

Working principle

It acts on the human body through the electricity pulse wave, the electric energy is sucked by the human body and the energy form is changed, which causes a series of physical and chemical changes, produces local or systemic physiological reactions, and finally affects the pathological process and plays a corresponding role.

Intended use

For TENS mode: To be used for temporary relief of pain and recovery of fatigue associated with sore and aching muscles due to strain from exercise or normal household work activities.

For EMS mode: To be used to stimulate healthy muscles in order to improve and facilitate muscle performance.

Applicable people

Adults who suffer from sore and aching muscles in the shoulder, waist, back, neck, upper extremities (arms), and lower extremities (leg) due to strain from exercise or normal household work activities can use this device.

However, it should not be used by children, pregnant women, or anyone who has an implanted metallic or electronic device. Ask your physician if you have any questions.

Package contents

Items	Quantity
Device	1 pc
Manual	1 pc
lead wires with 2 connectors (2.5mm)	2 pcs
large self-adhesive electrode pads	1 pair
medium self-adhesive electrode pads	3 pairs
small self-adhesive electrode pads	1 pair
USB cable	1 pc
Storage bag	1 pc

Features

- 24 modes
- 36 intensity levels
- 20-minute default timer, adjustable from 10-80 minutes or continuously

2.SAFETY INTRODUCTIONS

Warnings

(DO NOT USE THIS UNIT UNDER BELOW CONDITIONS:)

- Do not use this unit if you are using an implanted electronic medical device such as a pacemaker.
- Do not use this unit if you are wearing any electrode medical devices used for monitoring health functions.
- Do not use this unit while driving.
- Do not use this unit while sleeping.
- Do not use this unit in areas with high humidity such as a bathroom.
- Keep this unit out of reach of children.
- Do not use it on children or infants because the device has not been evaluated for pediatric use.
- Stop using this device and consult your physician at once if you feel pain discomfort such as dizziness or nausea.
- Do not attempt to move the electrode pads while the device is in operation.
- Do not use the device near the heart, on the head, near the mouth, genitals or blemished areas of the skin.
- Do not use this device over, or in proximity to, cancerous lesions.

- Do not use this device in the presence of electronic monitoring equipment (e.g., cardiac monitors, ECG alarms), which may not operate properly when the electrical stimulation device is in use.
- Pregnant women.
- Persons incapable of expressing their thoughts or intentions.
- Have epilepsy.
- Stop using this device and consult your physician if your pain does not improve, becomes more than mild, or continues for more than five days.
- Do not use this device over open wounds or rashes, or over swollen, red, infected, or inflamed areas or skin eruptions (e.g., phlebitis, thrombophlebitis, varicose veins).
- Can not be used after drinking.
- Low-frequency therapeutic instruments can not be used when using high-frequency surgical instruments.
- Near the genitals.
- Recommendation: do not use low-frequency therapeutic instruments near shortwave or microwave therapeutic equipment (e. g. 1m), where the output of the low frequency therapeutic instrument used is unstable.

- The high frequency surgical equipment and stimulator. When connected to a patient, burns may occur at the stimulator electrode and may damage the stimulator.
- Patients undergoing medical treatment and feeling abnormal.
- Heart patients with neurological abnormalities in the brain.
- Patients whose body temperature exceeds 38°C .
- Infectious diseases Patients.
- Patients who can not express their will.
- Do not use this product while charging.

Notice

Caution should be used in the presence of the following:

- Electrode wire is too long may cause suffocation. Keep the product and keep away from children.
- Make sure you are always aware of all warning items.
- Stimulators should not be used in the throat and mouth. This may result in severe throat muscle spasms and muscle contraction, which is sufficient to block the airway and cause dyspnea.
- The application of electrodes near the

thorax may increase the risk of cardiac fibrillation

- This stimulator should not treat unattended patients, or suffer from emotional distress, dementia, and low IQ people.
- Use guidance has been detailed; any improper use may lead to danger.
- Do not use this device for any undiagnosed pain symptoms, consult a doctor for diagnosis before use.
- Electrodes can not be placed in arteries, head and pubic area.
- Patients suffering from heart disease, cancer or other health-threatening conditions should consult a doctor before using this device.
- If the intensity of stimulation makes you feel 8 uncomfortable, reduce the intensity of stimulation to a comfortable level. If the problem remains, please contact your doctor.
- Do not use this equipment in rooms where aerosol (spray) and pure oxygen are used.
- Please do not use this equipment near any highly flammable substances, gases or explosives.
- Please check that the cable and related connections are in good condition before

each use.

- Turn off the device before using or removing the electrode pad.
- Electronic stimulator can only use electrode wires and electrodes recommended by manufacturers.







Consult your doctor before using the device especially in the following cases:

- Acute disease, especially patients suspected or suffering from hypertension, thrombosis or malignant mass.
- Patients with various skin diseases.
- Patients with chronic pain disorders (e. g. metabolic disorders) with reduced pain.
- Patients undergoing medication.

Adverse reaction:

- Skin allergies caused by electrode sheetpad gels and electrode irritation burns are potential adverse reactions. If the skin appears sensitive response, should be discontinued and consult your doctor.
- If the intensity of stimulation makes you feel uncomfortable, reduce the intensity of stimulation to a comfortable level, and if

Explanation of figures, symbols, warning statements and abbreviations on the equipment

Meanings of symbols used for marking described in instructions for use	
	Caution!
	Type BF applied part
	Direct current
IP22	Protected against solid foreign objects of 12,5mm Φ and greater; Protection against vertically falling water drops when ENCLOSURE tilted up to 15°
	Refer to instruction manual
	Serial Number
	Manufacture date
	Manufacture information

3.FUNCTIONS OF THE DEVICE

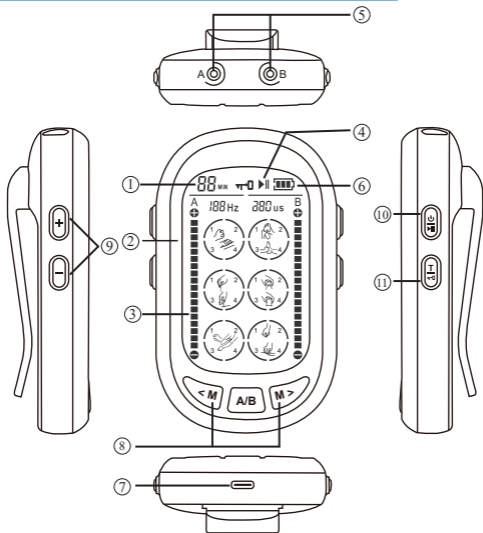

- ① Time indicator
- ② LCD screen
- ③ A/B channel intensity indicator
- ④ Pause indicator
- ⑤ A/B output
- ⑥ Battery indicator
- ⑦ Charging port
- ⑧ Mode selection button
- ⑨ Intensity adjust button
- ⑩ Turn on/off (Long Press) & Pause button (Short Press)
- ⑪ Time button (Short Press) & Lock button (Long Press)

4. OPERATING INSTRUCTIONS

BEFORE USING YOUR DEVICE

1. Please check if there are any damages to the device, electrode leads, or electrode pads.
2. Please ensure the electrode leads connection is not broken.
3. Please ensure that the device is fully charging.
4. When the device is in no-output status, it will automatically shut down if there is no further action within 5 minutes.
5. Clean your skin before use. Use the pads on clean and flat areas, no sweat and no oil.
6. Attach one pair or two pairs of the electrode pads to the massage area, such as the shoulder and leg.

Note: If the stickiness is not good enough after a period of use, please try to add a few drops of water on the pads and dry the pads naturally. It can increase their longevity. Make sure both pads on the skin do not overlap.

HOW TO USE

STEP 1: Connecting electrode pads to electrode wire. (IMG.1)

Note: Please check the snap connections to ensure they are fastened. Use at least one pair of pads, one pad can't work alone.

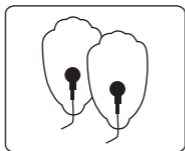

IMG.1

STEP 2: Paste electrode pads to the area where you want therapy. (IMG.2)

Note: When using 1 wire with 2 connectors, please make sure both pads are stuck on your body; when using 2 wires, please make sure at least 2 pairs of pads are stuck on your body. Please confirm the wire is plugged well and pads are stuck to your skin before adjusting the unit.

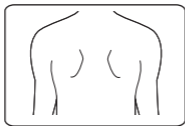

IMG.2

STEP 3: Connecting electrodes wire to the device (channel A/B). (IMG.3)

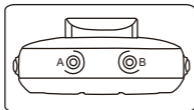

IMG.3

STEP 4: Long Press the upper-right “Power/Pause” button to turn on device(PS: Short Press is for the pause function)(IMG.4)

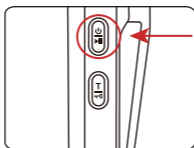

IMG.4

STEP 5: Press “A”/ “B” button to choose A or B channel mode. (IMG.5)

Please check the flash channel indicator on the screen to make sure it is the channel you want to use. The flash "A" icon indicates you can adjust the mode and intensity level of Channel A. If you choose Channel B, the Channel B icon will flash to indicate the Channel B is working.

Note: A/B two channel all independent you can set different mode and intensity on different channel.

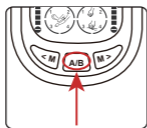

IMG.5

STEP 6: Short press <M ,M> button to choose the mode you like. (IMG.6)

Note: Remember the intensity will default to Zero when changing the modes. It is recommended to start with the lowest level of intensity and gradually increase to a level that is comfortable.

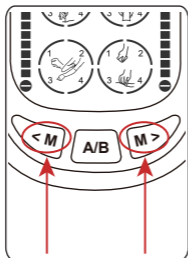

IMG.6

**STEP 7: Short press upper-left button “+”
“-” button to adjust A/B intensity)
(IMAG.7)**

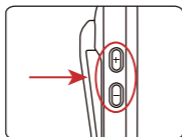

IMG.7

**STEP 8: Short press upper right-side
Time/Lock button to set the
time (PS: Long Press is for the
lock function)(IMG.8)**

The default time is 20mins. Short Press the “Time/Lock” button to adjust the time (10-80mins), it can

be increased by 10mins. When it's increased up to 80mins, continue to press the "T" button to jump to 10mins.

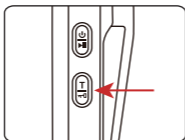

IMG.8

STEP 9: Long Press the Time/Lock button to lock the unit after you complete the above settings (PS: Short Press is for time setting)(IMG.9)

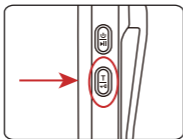

IMG.9

STEP 10: Long Press the Power/Pause button to turn off device if no need to use it(PS: Short Press is for the pause function)(IMG.10)

The device will automatically turns off when the time runs out.

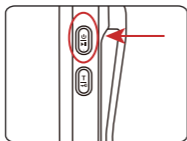

IMG.10

STEP 11: Remove the pads from your skin and store the products

Remove the pads from you skin gently, and paste the plastic dust-proof film on them, take them off the electrode wires and unplug the wires, put them and the device into the storage bag.

Note: Please don't tear off the pads vigorously. Please don't remove the pad before turning off the device.

5.BATTERY AND MEMORY FUNCTION

·Battery information

Please use the AC adapter complying the standard : IEC60601-1, DC5V/1A)

Capacity: 180 mAh

Frequency: 1-110HZ

Voltage: 3.7V

·Charging the battery

- 1.The device is powered by an internal, rechargeable lithium battery that can be charged through a standard wall outlet or through the USB port of a computer or power bank. Signs the device needs to be charged include dimness of the screen or failure to display the screen, and weak sensations from the electrodes.
- 2.Turn off the device.
- 3.Connect the controller and the charger with USB extension cord.Plug charger into any power outlet. The charging process will last 1-2 hours.

·Memory function

The memory function can help to remember the selected mode, the Mode will always be the same as the value as before pause and shut down.

6.MAINTENANCE

Please clean the main machine frequently. Use a piece of soft dry cloth to wipe the dirt on the main machine. Don't wash with water or clean with the detergent, thinner, volatile oil, etc. that contains chemical substances.

The gel surface of the massage pad should be kept clean and avoid dirt like dust, oily substances, sticky substances, etc., otherwise the stickiness will be decreased. Please put the massage pads back to the pad holders or paste the protective films back onto the pads after use.

When the stickiness of the massage pad becomes weak due to dirt or if there is a tingling sensation in the skin, please use a piece of damp cloth dipped in a little water to gently wipe the gel surface. After drying, the stickiness will recover, but if water is overused, the stickiness will be decreased. Please don't wipe the gel surface with a paper towel.

Please do not scrape the gel surface with nail, brush, etc.

Massage pads are consumables with the service life of generally 20-30 times. If the pads are not sticky or the pulse becomes weak, please change the pads in time.

The batteries for this product are built-in polymer batteries. If it is not used for a long time, please charge it every 6 months.

Safekeeping

Please do not put the main machine in the place exposed to sunlight, high temperature, humidity, lots of dust, or the place close to fire, easy to vibrate or shock. Please put where children can't reach it.

Cleaning and storing pad

Clean: After using pads on your body, please drop a little clean water on the sticky side and use fingertips to clean it softly

- Please turn off the device and disconnect the pads with wires first before you clean the pad.
- Do not use nails or other sharp objects on the sticky side. Do not use chemical liquids on sticky side.

Storage: Place pads on pad holder or place plastic film on the sticky side of pad to keep the gel moisture.

- Do not keep device in areas subject to direct sunlight, high or low temperatures, humid area, near to fire, vibration, or shock.
- Do not keep the device at places that can be easily reached by children.

★ WARM TIPS FOR SKINCARE



To avoid skin irritation, especially if you have sensitive skin, follow these suggestions:



1. Wash the area of skin where you will be placing the electrodes, using mild soap and water before applying electrodes, and after taking them off. Be sure to rinse soap off thoroughly and dry skin well.
2. Excess hair may be clipped with scissors; do not shave stimulation area.
3. Wipe the area with skin preparation wipes. Let the area dry. Apply electrodes as directed.
4. Many skin problems arise from the "pulling stress" from adhesive patches that are excessively stretched across the skin during application. To prevent this, apply electrodes from centre outward; avoid stretching over the skin.
5. To minimize "pulling stress", tape extra lengths of lead wires to the skin in a loop to prevent tugging on electrodes.
6. When removing electrodes, always remove by pulling in the direction of hair growth.
7. It may be helpful to rub skin lotion on electrode placement area when not wearing electrodes.

8. Never apply electrodes over irritated or broken skin.

7.MODE INSTRUCTION

Modes & Functions

Main Mode	ICON	Description
Main Mode 1: Tapping		Stimulating tapping is intended to produce a hard thumping sensation that massages your muscles, which can give you an invigorated and revitalized feeling.
Main Mode 2: Shiatsu		Shiatsu is simulation of a type of finger and palm pressure, stretches, and other massage techniques.
Main Mode 3: Acupuncture		Simulation of acupuncture provides the same sensation without needles, by utilizing electronic pulses to achieve the sensation of differing needle depths.

<p>Main Mode 4: Cupping</p>	 <p>The diagram shows two hand positions within a circular frame. Position 1 shows a hand holding a cup over the skin. Position 2 shows the cup being pressed against the skin. Position 3 shows the cup being lifted, creating suction. Position 4 shows the cup being held against the skin.</p>	<p>Mimic the sensation of suction created on the skin. Cupping is a traditional Chinese therapy in which heated glass cups are applied to the skin, creating suction as a way of stimulating the flow of energy.</p>
<p>Main Mode 5: Tui na</p>	 <p>The diagram shows two hand positions within a circular frame. Position 1 shows a hand holding a tool (like a brush or stick) against the skin. Position 2 shows the tool being moved across the skin. Position 3 shows the tool being lifted. Position 4 shows the tool being held against the skin.</p>	<p>Simulation of Tuina is a hands-on body treatment which help with muscle pain relief and relaxation.</p>
<p>Main Mode 6: Scraping</p>	 <p>The diagram shows two hand positions within a circular frame. Position 1 shows a hand holding a tool (like a brush or stick) against the skin. Position 2 shows the tool being moved across the skin. Position 3 shows the tool being lifted. Position 4 shows the tool being held against the skin.</p>	<p>Stimulate pain points in the elbow area for pain relief or muscle relaxation.</p>

8.TENS EMS ELECTRODE PLACEMENT GUIDE

For TENS

Neck Pain



Chronic Hip Pain



Frozen Shoulder



Lower Back Pain



Tennis Elbow



Carpel Tunner Syndrome



Stomach Pain



Erector Spinalis



Sciatica



Knee Pain-Post OP



Degenerative Arthritis-Knee Pain



Lower Leg Pain



Foot Pain



**General System Nerves, Muscle, Tiredness
& Bad Blood Circulation**



Ankle Pain



For EMS

SDDL



QUADRICERS & GRACILIS



ABDOMINALS



FRONT DELTOIDS



HAMSTRINGS



OBLIQUE



BICEPS



GLUTEUS MAXIMUS



LATISSIMUS DORSI



VASTUS MEDIALIS



GALVES



TRAPEZIUS



VASTUS LATERALIS



FOREARMS



9.TROUBLESHOOTING

Problems	Causes	Solutions
Skin feels a painful burning sensation, or the stimulation becomes weakened.	Adhesive gel pads are not adhering firmly to the skin. The gel pads are too dry.	Apply a few drops of water to the adhesive surface of each pad and make sure the pads are pressed firmly to the skin during application
Unit is on, but no sensation is felt from the pads.	Both pads are not firmly on the skin. There is a loose connection. The intensity level needs to be increased.	Make sure all pads are firmly pressed to the skin. Make sure all connections are well from the unit to the wires and the wires to the pads. Increase the intensity level.
Adhesive gel pads do not stick to skin even after cleaning and moistening the gel pad.	Adhesive gel pads need to be replaced.	Replace the pads. You can contact support@belifu.com to purchase the pads.
Unit does not turn on or the screen is dim.	Battery is low.	Recharge the battery.
Does not provide adequate pain relief.	Not using it long enough.	Use your massager 20-30 minutes at a time, 3-6 times per day.

<p>Unit turns on, all of the modes and channels flash. Can not select a mode and adjust the intensity.</p>	<p>Always use two pads (one channel) or four pads (two channels) at the same time as it will not work with just one pad or three pads.</p>	<p>When you use two pads (one channel) or four pads (two channels) at the same time, make sure you have placed all pads on your body, otherwise it won't work.</p>
<p>The pluses strong on one side and weak on the other side.</p>	<p>Different nerve distribution in different parts of the body, different skin sensitivity, or insufficient skin contact with the electrodes.</p>	<p>Please wipe the skin with a wet towel before use to ensure adequate contact with the electrode. It suggested that the two electrodes should be symmetrical when attached to the body</p>
<p>Key failure</p>	<p>The machine is locked or paused.</p>	<p>Press the "LOCK" key to unlock the device or press the "PAUSE" key to continue the treatment.</p>
<p>Feeling unwell</p>	<p>Too strong. Too close between electrodes.</p>	<p>Electrodes or conductors are damaged. The electrode area is too small. Decrease intensity. Reorient electrode position. Replace the electrode wire or pads.</p>

10.PRODUCT DESCRIPTIONS

Product name	TENS
Model	YF1503
Charge time	About 2 hours
Battery run time	About 8 hours
Lithium battery power supply	3.7V/180mAh
Load resistance	500Ω
Output frequency	1Hz~110Hz
Maximum pulse width	180uS
Velocity Pulse Amplitude	0~98 Vpp
Low voltage protection	MAX≤3.3V
Weight	102g
Size	(L)110mm*(W)65mm*(H)18mm
Number of channels	2
Treatment time	10-80mins
AC adapter	110V-240V
Charging interface	TYPE-C USB
Display	LCD liquid crystal
Operating environment temperature	5℃ ~40℃ (41.0 ℉ ~104 ℉)
Battery capacity	180mAH

11.MEDICAL DISCLAIMER

All information is intended for you general knowledge only and is not a substitute for medical advice or treatment for specific medical conditions. We cannot and do not give you medical advice. You should seek prompt medical care for any specific health issues and consult your health care provider before purchasing any product(s). The information contained here is intended to provide broad consumer understanding and knowledge of product offered.

The information should not be considered complete and should not be used in place of a visit, call, consultation or advice or your health care provider. Should you have any healthcare-related questions, please call or see your health-care provider promptly. You should never disregard medical advice or delay in seeking it because of something you have read here.

Precautions to be taken in the event of changes in the performance of me equipment or me system

Me equipment, me systems and accessories require professional hygienic maintenance prior to re-use. When the ME equipment is transferred to another patient, please contact us for the relevant service.

Disposal Information

Please contact the local authorities to determine the proper method of disposal of the used equipment and accessories.

12.PRECAUTIONS

- 1.Safety of this device for use during pregnancy has not been established.
- 2.Caution should be used for patients with suspected or diagnosed heart problems.
- 3.Caution should be used for patients with suspected or diagnosed epilepsy.
- 4.Caution should be used in the presence of the following:
 - When there is a tendency to hemorrhage following acute trauma or fracture;
 - Following recent surgical procedures when muscle contraction may disrupt the healing process;

- Over the menstruating or pregnant uterus;
 - Over areas of the skin which lack normal sensation.
5. Some patients may experience skin irritation or hypersensitivity due to the electrical stimulation or electrical conductive medium. The irritation can usually be reduced by using an alternate conductive medium, or alternate electrode placement.
 6. Electrode placement and stimulation settings should be based on the guidance of the prescribing practitioner.
 7. The device should be kept out of the reach of children.
 8. The device should be used only with the leads and electrodes recommended for.
 9. This device should not be used while driving, operating machinery, or during any activity in which involuntary muscle contractions may put the user at undue risk of injury.

13. CONTRAINDICATIONS

Do not use this device if you have an implanted electronic device, i.e. a cardiac pacemaker, implanted defibrillator, or other

implanted metallic or electronic device unless specialist medical opinion has first been obtained. Such use could cause electric shock, burns, electrical interference, or death.

14.ADVVERSE REACTION

- Skin irritation and burns beneath the stimulation electrodes applied to your skin.
- Headache and other painful sensations during or following the application of electrical stimulation near your eyes, to your head and face.
- Potential allergic reactions due to the electrical stimulation or gel including: skin irritation, redness, burning or hypersensitivity.

*** You should stop using the device and consult with your physician if you experience any adverse reactions from the device. ***

Potential Electromagnetic and Other Interference

This product is sensitive to the electromagnetic interference, and the following cases may interfere with normal use:

- When talking on the mobile phone;

- Near the base station for signal transmission (broadcast, television, communications, radar, navigation, etc.);
- Near high radiation medical instruments such as nuclear magnetic resonance;The operator should be away from the equipment or occasion as soon as possible if the essential performance of the equipment is degraded or lost due to EM DISTRUBANCES. The essential performance of the equipment should be restored. If not, please contact your seller.

15.NOTES ON FCC CERTIFICATION

This device has been tested and found to comply with the limits for a Class B digital device, pursuant to part 15 of the FCC Rules. These limits are designed to provide reasonable protection against harmful interference in a residential installation. This device generates uses and can radiate radio frequency energy and, if not installed and used in accordance with the instructions, may cause harmful interference to radio communications. However, there is no guarantee that interference will not occur in a particular installation. If this device does

cause harmful interference to radio or television reception, which can be determined by turning the equipment off and on, the user is encouraged to try to correct the interference by one or more of the following measures:

- Reorient or relocate the receiving antenna.
- Increase the separation between the equipment and receiver.
- Connect the equipment into an outlet on a circuit different from that to which the receiver is connected.
- Consult the dealer or an experienced for help.
- Consult the seller or **support@belifu.com** for help.

Any Changes or modifications not expressly approved by the party responsible for compliance could void the user's authority to operate the device.

16.WARRANTY

- 1) The warranty period for device is two year from date of delivery. In case of a warranty claim, the date of delivery has to be proven by means of the sales receipt or invoice.
- 2) Repairs under warranty do not extend the warranty period.
- 3) The following cases are not included in the warranty.
 - All damage which has arisen due to improper treatment, e.g. nonobservance of the user instruction.
 - All damage which is due to repairs or tampering by the customer or unauthorized third parties.
 - Damage which has arisen during transport from the manufacturer to the consumer or during transport to the service centre.
 - Accessories which are subject to normal wear and tear.
- 4) Liability for direct or indirect consequential losses caused by the unit is excluded even if the damage to the unit is accepted as a warranty claim.
- 5) Anything about the device, please feel free to contact **support@belifu.com**